

HP 50
 & , \$+ ! ' A 9F 5H9 ! @7
 J] U ' 9b f] Wc : Yfa]z' %
 +5 @5

589; I 5A 9BHC I B =%\$(%#I B =9B ; %&\$
 : fYbc Uf[Ubc : 59F 'D) , : ! ' gYfY %
 9YHfca U[bYH' Wc b' bi WY]]bX] dYbXYbh
 Y Wc bU H] Wc b f c ` c ' d c g h] c b Y [Ub Ug W

BH\$+(*

FYj]c bY	% (# \$ & # & \$ & (
7 ca d] Urc	@A "
5 d d f c j Urc	
Uæ BwWwã '	

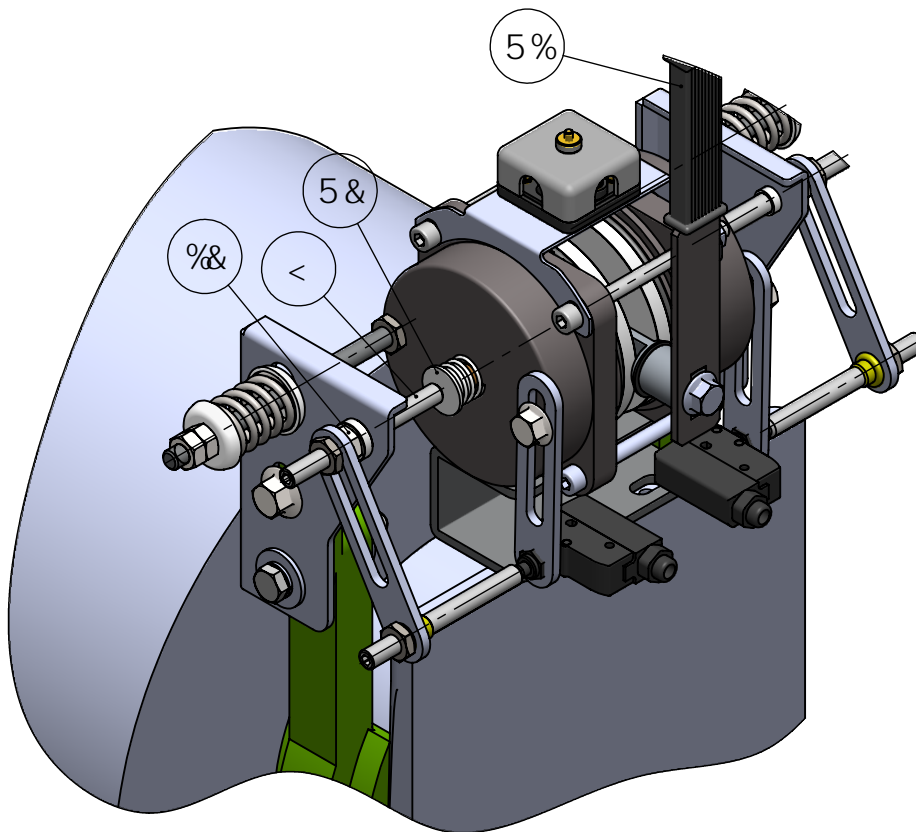

k-8\O -@V-) -07k-V\

@
 O
) U @
 k
 .. U
 o k =
 k =
 .. =
 " U
 #
 U
 @
 #
 @
 # = @ o \
 o = V \ V) - t -

E.I. 0642 8.69. BC 995-DEC-DF-94H/900MS-HP/50GT
 8.4.46C 8.4f BFC 8.1.16.99.93-8.1.16.5146
 BHP/50-@Y&#(1% (, B5* . E

