

H@5@
 &' \$+! 'A 9F 5H9! @7
 J]U' 9b]M c : Yfa]z' %
 +5 @5

589; I 5A 9BHC 'I B =%\$(%&!%I B =9B ; ,%&\$
 : fYbc 'Uf[Ubc 'G7 < B 8 @9F 'K %*'
 9YHfca U[bYH' Wc b' bi WY]]bX] dYbXYbh]
 Y Wc bU]h] Wc b]fc `c 'd c g]c bY ' [UbUgW

BH\$(')

FYj]c bY	5 ! '\$%# ' #&\$&('
7 ca d]Urc	@A "
5 d d f c] Urc	
Uae EW W W W W	

7C8.; %\$ - %\$ '! ; \$J VW

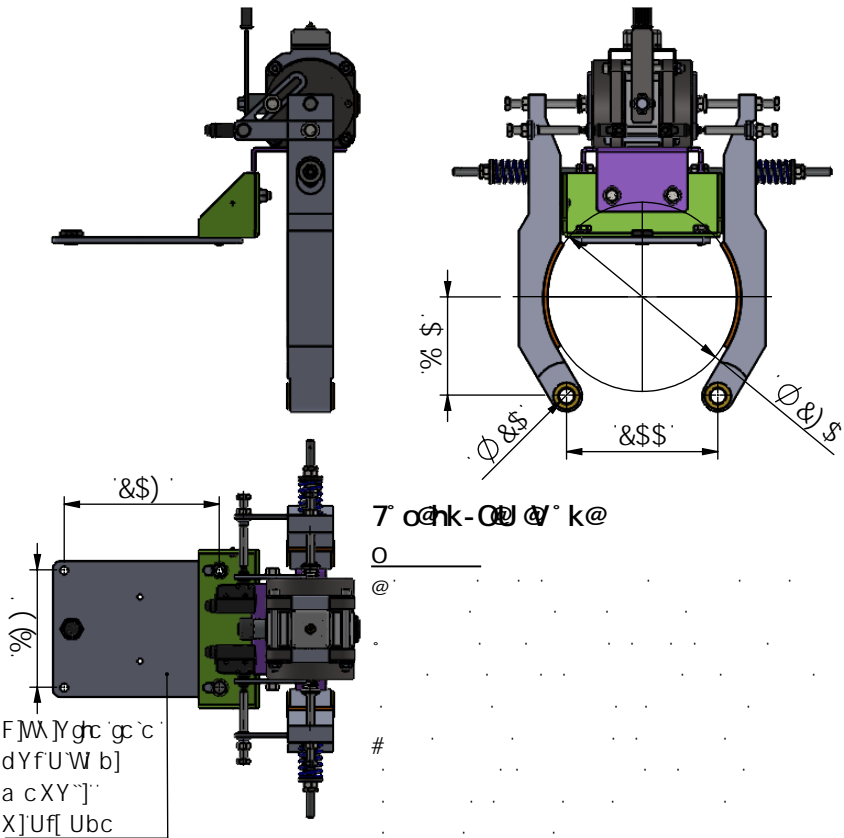

7 C B H B I H C 7 C B : 9 N C B 9		
Dcg'	8Yg]nc bY	E 'h
5	9YHfca U[bYH' 9&! ZYbc ; \$J	%
6	7 cdYfM]c 'a UWM]bU	%
7	GUZU'X] ZggU []c	%
8	G d d c f c Y Y H f c a U [b Y H	%
9	; UbUgWU Wca d'YH'K %'	&
9%	J]H' H9A %\$! - \$	(
:	D]Ug]bU Wc bU]rc	&
:	D]Ug]bU [UbUgW d'YfWc bU]h]	&
<	A c`U 0' & * (' 6 @ ' WU]M c ' a YX]c	&
=	'H]bH' A %\$! % \$	&
A	A]M c Wc bU]rc	&
B	6i ggc 'U'Y [[]a c`U	&
%	J]H' H9A %\$! &]ZUb []U]U' 8-B * - &%	*
%(J]H' H9A %\$! %*	&
%)	Fcg'HU d]UbU %\$) I &%	%\$
%*	Fcg'HU Y Ug]WU '5 %\$ n]bW	*
%+	J]H' H9A %\$! & ! ; ' I B 3 + ' + n]bW	&
%	8UXc Yg' A %\$ VUggc	(
%-	8UXc A %\$,
&\$	8UXc YgU [" A %\$ ZUb []Urc	&
&%	J #9H %\$! ' \$I B =) + ' - n]bW	&

E I 9GFC 8 69; B C 9RS ; D C D F 9H F 99 9MS ; H 99 5 @ G T
 8 H 4FC 8 H F 9FC 8 H M 99 99 8 H I @ 5 N C B 9
 F9 H 9 L - @ [Y 9 9 I (% ; + B 5 * ; E

h
o
k

@ai 0 - @ V -

o
U
" U
o " #
U) #
U U) U
U U) U
@) U)
U)
@ = V
U @
y U
h

7y\k@-kt@a

